

EXECUTIVE SUMMARY

FOR
EXPANSION OF STEEL MANUFACTURING UNIT

M/S J N TAYAL PVT LTD

**VILLAGE- BHAGWANPURA, DEHLON ROAD TEHSIL- LUDHIANA EAST,
DISTRICT- LUDHIANA, PUNJAB.**

Prepared by
Chandigarh Pollution Testing Laboratory- EIA Division

(QCI/ NABET Certificate No: NABET/EIA/1922/RA 0146)

Address: E- 126, Phase- VII, Industrial Area, Mohali, Punjab- 160055.

Contacts: 0172-4669295, 5090312

E-mail: eia@cptl.co.in / cptleia@gmail.com

Website: www.cptl.co.in

November, 2020

EXECUTIVE SUMMARY

1.0 Project Name and location

The Proposed Project i.e. M/s JN Tayal Pvt. Ltd. is a Secondary Metallurgical Process based industry. The plant is located at Village- Bhagwanpura, Dehlon Road Tehsil- Ludhiana East, District- Ludhiana, Punjab.

2.0 Products and capacities

It is proposed to enhance the capacity by upgrading of 2 no's of Induction furnaces of capacity 1X10 and 1X15 TPH,, a Concast Machine and Rolling Mill of capacity 15 TPH. The capacity of the Steel Ingots/Billets unit after expansion will be 1, 05,000 TPA and 1, 00,000 TPA of MS Rounds, Bars.

After expansion the production details will be as under:

Product Name	Existing (TPA)	Proposed (TPA)	Total (TPA)
Alloy/Non Alloys Steel Billets/ Ingots	29,610	75,390	1,05,000
Structural Steel (Round, Coil, Flats, Wire Rod, TMT Bars)	Nil	1,00,000	1,00,000

3.1 Land Area

The industry is having 2.85 acres of land. No additional land will be required for expansion

3.2 Raw Material Requirement

RAW MATERIAL			
Capacity	Existing	Additional	Total
MS Scrap (TPA)	32,500	82,900	1,15,400
Ferro Alloys (TPA)	1050	3,150	4,200
Source & Transportation	Local & international markets and transport through covered trucks		

3.3 Water Requirement

Water consumption in the unit shall be for twin purpose namely domestic and make up water

for cooling tower (CT). Water requirement will be met through existing tube well. The detail of water requirement and water balance is given below:-

Water Requirement

DESCRIPTION	EXISTING (KLD)	PROPOSED (KLD)	TOTAL (KLD)
Domestic	4.5	3.0	7.5
Cooling (makeup water)	8.0	15.0	23.0
Total	12.5	18.0	30.5

3.4 Power Requirement

The Power Requirement will be met by sourcing the power from Punjab State Power Corporation limited from nearby Sub-station. The detail of power requirement existing & after expansion is given below:-

Power Requirement

DESCRIPTION	EXISTING (KW)	PROPOSED (KW)	TOTAL (KW)
Power	4000	12000	16000
Source	Punjab State Power Corporation Limited, Punjab		

3.5 Manpower Requirement

For expansion, additional 55 persons will be required. Total manpower after expansion will be 100.

4.0 Process Description

FLOW DIAGRAM OF PROCESS

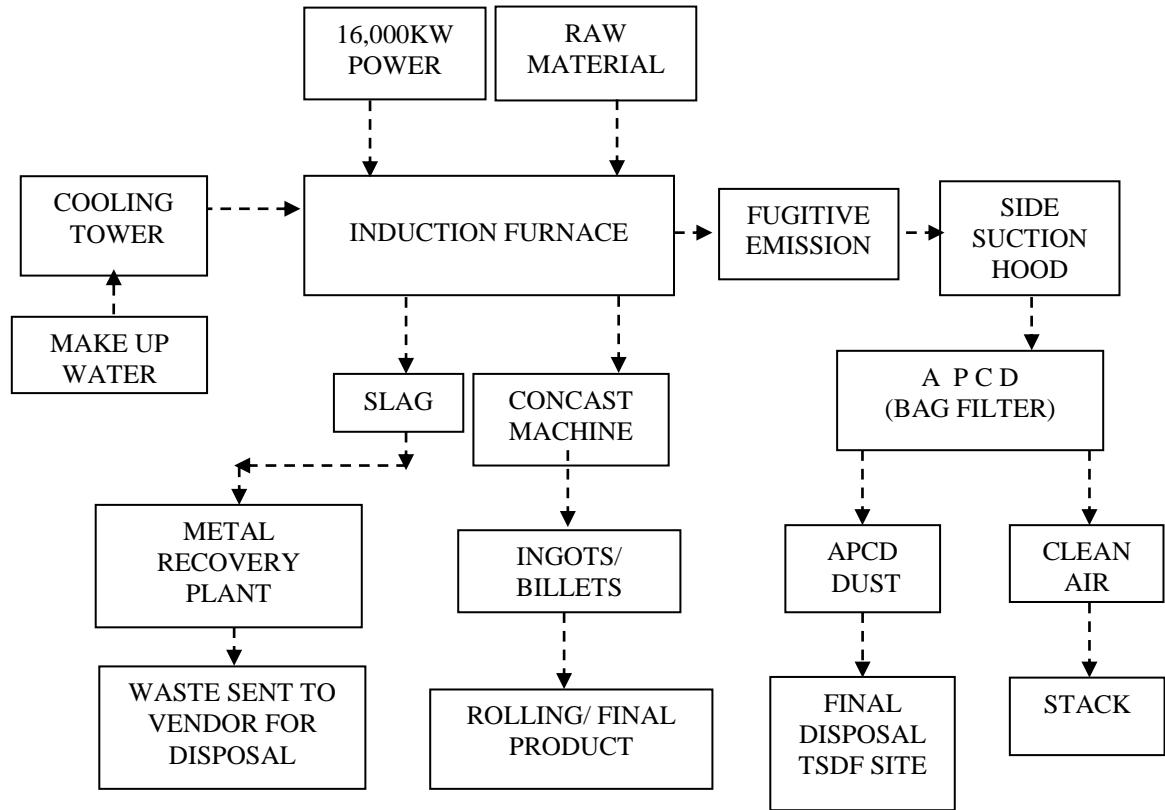

Material Balance

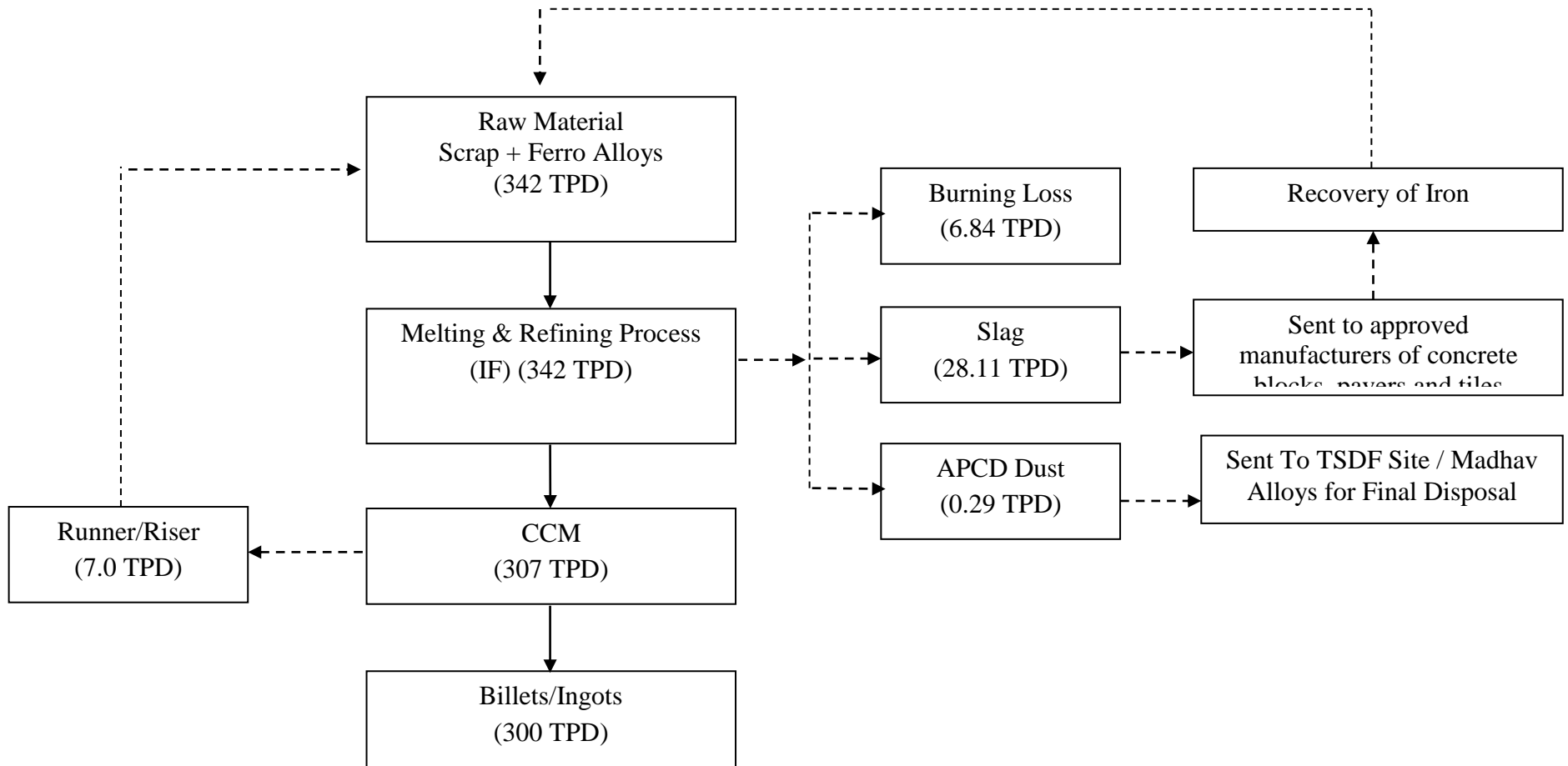

5.0 Description of Mitigation Measures

The purpose of mitigation measures is to avoid, reduce or minimize unwanted impacts on the environment. To minimize & control the emission from I.F, the exhaust after suction through side suction hood is passed through spark arrestor, air cooling and finally bag filters before its discharge to atmosphere. DG set is fitted with a canopy and adequate stack to take care of noise and particulate & gaseous emission. About 28.11 TPD of slag which is not a H.W will be generated and the same after recovering of iron will be supplied to manufacturers of cement concrete blocks, pavers & tiles under proper agreement. Treated waste water from STP will be used for plantation within the industrial premises. About 0.29 ton/day APCD dust will be also covered under hazardous waste and sent to M/S Madhav Alloys (P) Limited or TSDF site Nimbuan Dera Bassi for final disposal.

6.0 Cost Details

The total cost of the project after expansion will be Rs 12.91 Crores including Rs 8.0 Crores as cost of expansion. The proposed expansion will be done within one year after granting of Environment Clearance.

7.0 Site Details

M/s J.N. Tayal Steels Pvt. Ltd. is situated at Village- Bhagwanpura, Dehlon Road Tehsil- Ludhiana East, District- Ludhiana, Punjab having its global coordinates as Latitude 30°47'43.57"N;30°47'43.47"N,30°47'41.80"N;30°47'41.80"N

& Longitude 75°56'38.92"E; 75°56'30.28"E , 75°56'30.78"E; 75°56'38.87"E. Ludhiana is the nearest city (about 14 Km) and also the railway station (about (9 Km). Nearest airport is Ludhiana which is at 6 km from site. No National Parks/ Wildlife Sanctuaries/ Biosphere Reserves/ Reserved Forests exist within 10 km radius of project site.

site

8.0 Baseline Environmental Data and their impacts

Various Environmental factors as existing in the study area which are liable to be affected by the activities have been assessed both quantitatively and qualitatively. Baseline environmental data generation of study area was carried out during the period January-March, 2020.

8.1 Ambient Air Quality

The PM_{2.5}, PM₁₀, SO₂, NO₂, CO levels were monitored at eight locations in the study area for four months (January 2020 to March 2020). The P98 levels of criteria pollutants are as follows: PM_{2.5} is 54.3µg/m³, PM₁₀ is 96.37µg/m³, SO₂ is 15.8µg/m³, NO₂ is 28.7 µg/m³ and CO is 0.69mg/ m³. The baseline air quality level is within the National Ambient Air Quality

Standards prescribed for industrial, residential, rural & other area and also satisfies the air quality index (AQI) w.r.t. health bracket for all the monitoring. (**Standards are 60, 100, 80, 80 $\mu\text{g}/\text{m}^3$ and 4.0 mg/m^3 for $\text{PM}_{2.5}$, PM_{10} , SO_2 , NO_x and CO respectively**). Due to better pollution abatement facilities, proposed expansion will have insignificant impact on existing air quality.

8.2 Water Quality:

Eight groundwater samples and one surface water sample were collected from the study area for physical, chemical and bacteriological analysis. The groundwater quality of the study is satisfactory. No physical or bacterial contamination was found in the water quality. But bacterial contamination is found in surface water. Since, no waste water will be discharged on land, water quality is not likely to be impacted.

8.3 Noise Environment

Ambient noise levels were monitored at 8 locations in the study area. Noise levels in the study vary from 46.1 dB (A) to 70.4 dB (A) in day time and 34.2 dB (A) to 65.9 dB (A) at night. The highest levels were observed at Project Site. The baseline noise levels are well within the National Standards. Proposed expansion will have less impact than existing one due to better pollution control facility.

8.4 Soil Quality

Eight soil samples were collected from the study area and analyzed. The texture of soil is sandy loam. The organic matter, nitrogen, potassium and phosphorus content of the soil are moderate. The pH of all the soil samples is within the acceptable range. No impact on soil will be there for proposed plant.

8.5 Ecological environment

Ecological data has been collected through secondary sources and by site visits. The tree species kikar, Jamun, Peepal and Mango etc are the dominant plant species of the study area. Mongoose, porcupine, jungle cat, cobra, krait, snakes, hare, pigeon and variety of birds are the common animals of the study area. No endangered species of plants and animals are found in the study area, so no impact on ecological environment

8.6 Sensitive Ecosystem:

Within 10 km distance of the project site, no plant or animal species were found to be on the endangered list. No ecologically sensitive area like biosphere reserve, tiger reserve, and elephant reserve, migratory corridors of wild elephant, wetland, national park and wildlife

sanctuary are present within 10 km distance of the project site. There is no Reserve and Protected Forests present around the project site of 10 km. Agriculture and industrial workers dominate the occupation structure of the study area. Several induction furnaces, rolling mills, ferroalloy plants, brick kilns, and other small units are present in the study area.

8.7 Socioeconomic Condition:

Socioeconomic status has been studied through secondary sources and by site visits. The social requirements identified such as Drinking water requirement, Promotion of Educational institutions and Medical facilities to the villagers (especially Senior Citizens and infants or pregnant ladies). Community centers, recreation facilities etc will also be developed as part of social responsibility.

9.0 Possible Hazards & Risks from Secondary Metallurgical Industries

The various process operations, which are having potentially high risk to human exposure and which have high levels of attention area identified in **Table**.

Table: Possible Risk

S.No.	Plant Area	Possible Deviation from normal operation	Likely Causes	Consequences
1	Furnace	Re-circulating and cooling water coming in contact with the molten iron or slag.	Leakage of water from the walls Spurting of metal/ slag.	Explosion under extreme cases.
		Presence of Oil & Grease and other Impurities in raw materials.	Fire	Sudden catches fire & flames
2	High Power Transformer	Oil temperature being very high.	Varying room Temperatures.	Sudden flashing of fire or bursting.

3	High Tension Electrical Installation	Heavy sparking at the pot heads and the joints.	Loose joints, cable cut, burning of fuses, short circuits etc.	Sparks in the beginning, devastating fire if neglected.
---	--------------------------------------	---	--	---

10.0 Emergency Plan

Emergency planning is primary for the protection of plant personnel and people in nearby areas and the environment that could be affected by unplanned hazardous events. Furnaces are associated with fire and electrical hazard due to sudden generation of pressure or temperature that leads to damage, injury and death. Temperature and pressure are closely related, and when flammable or combustible mixture is present in process equipment that leads to worst consequences. Thus, an engineering evaluation will be done for worst-case scenario.

11.0 CER Activities (Corporate Environmental Responsibility)

The company has earmarked Rs 8.0 lakhs towards the Corporate Environmental Responsibility for undertaking the environmental activities as defined in CER circular issued by MoEF & CC and the public hearing issues which will be detailed in final EIA report.

12.0 Environment Monitoring Plan

Regular monitoring of all significant environmental parameters is essential to check the compliance status vis-à-vis the environmental laws and regulation. The frequency of the monitoring will be as follows:

- The ambient Air quality shall be monitored at project site and two upward and downstream locations once every quarter for PM_{2.5}, PM₁₀, NO_x & SO₂, and CO levels during the Construction Phase and Operational Phase.
- The Ambient Noise Levels, Water Quality, Effluent etc. shall also be monitored once every six months or as per EC conditions.